

ITEM NO.	QTY.	PART NO.
1	1	Assembly, bulk bag unloading station (14881)
2	1	Assembly, bag dump - bulk bag (14881)
3	1	20 dia flexible connection
4	1	Chain hoist (14881)
5	1	48 sq. x 10 low profile lift bracket
6	1	Rotary valve assembly (14881)
8	1	Assembly, bag dump work platform
9	1	Assembly, Stinger, right angle (14881)
10	1	Control panel (14881)

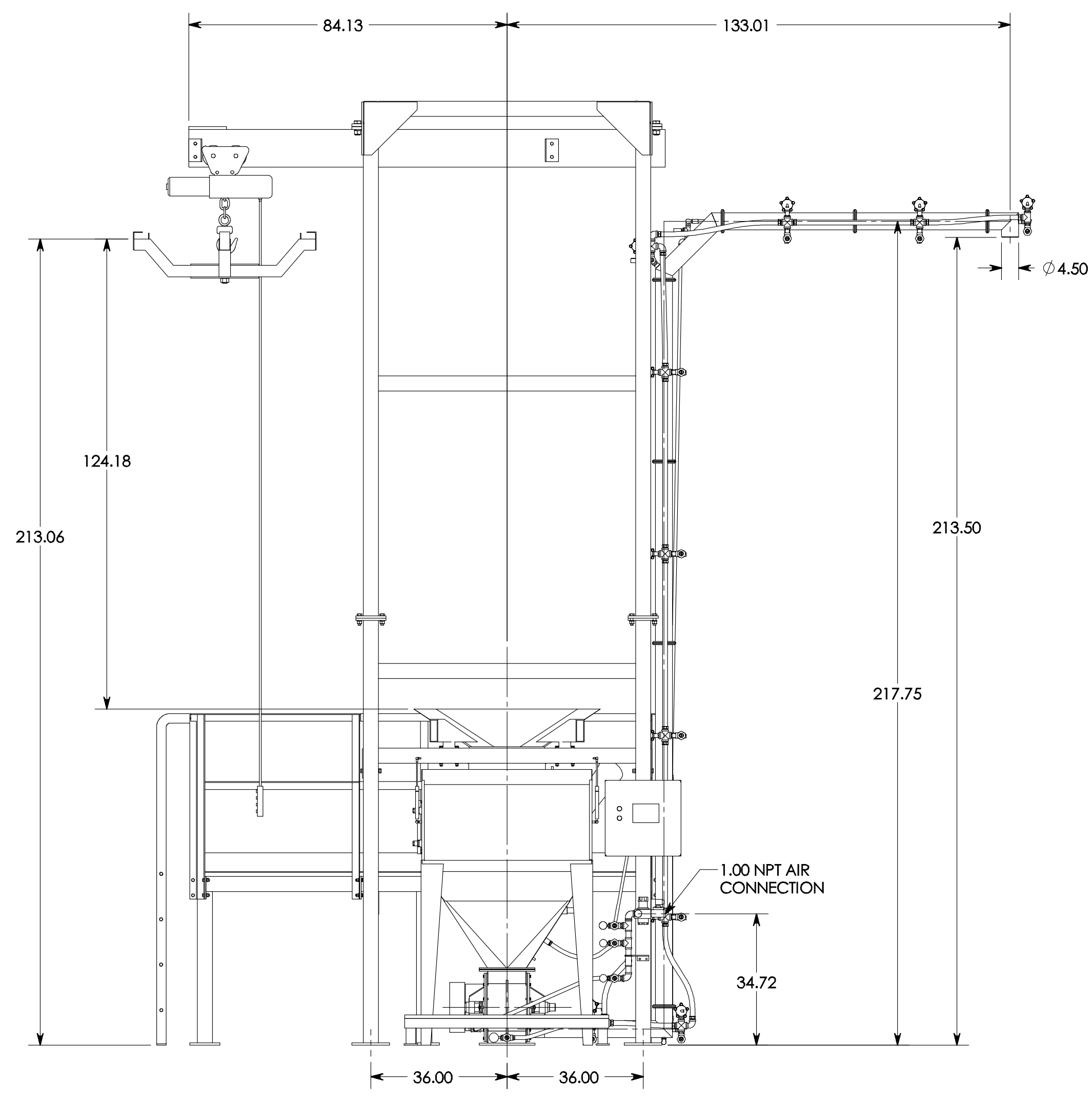
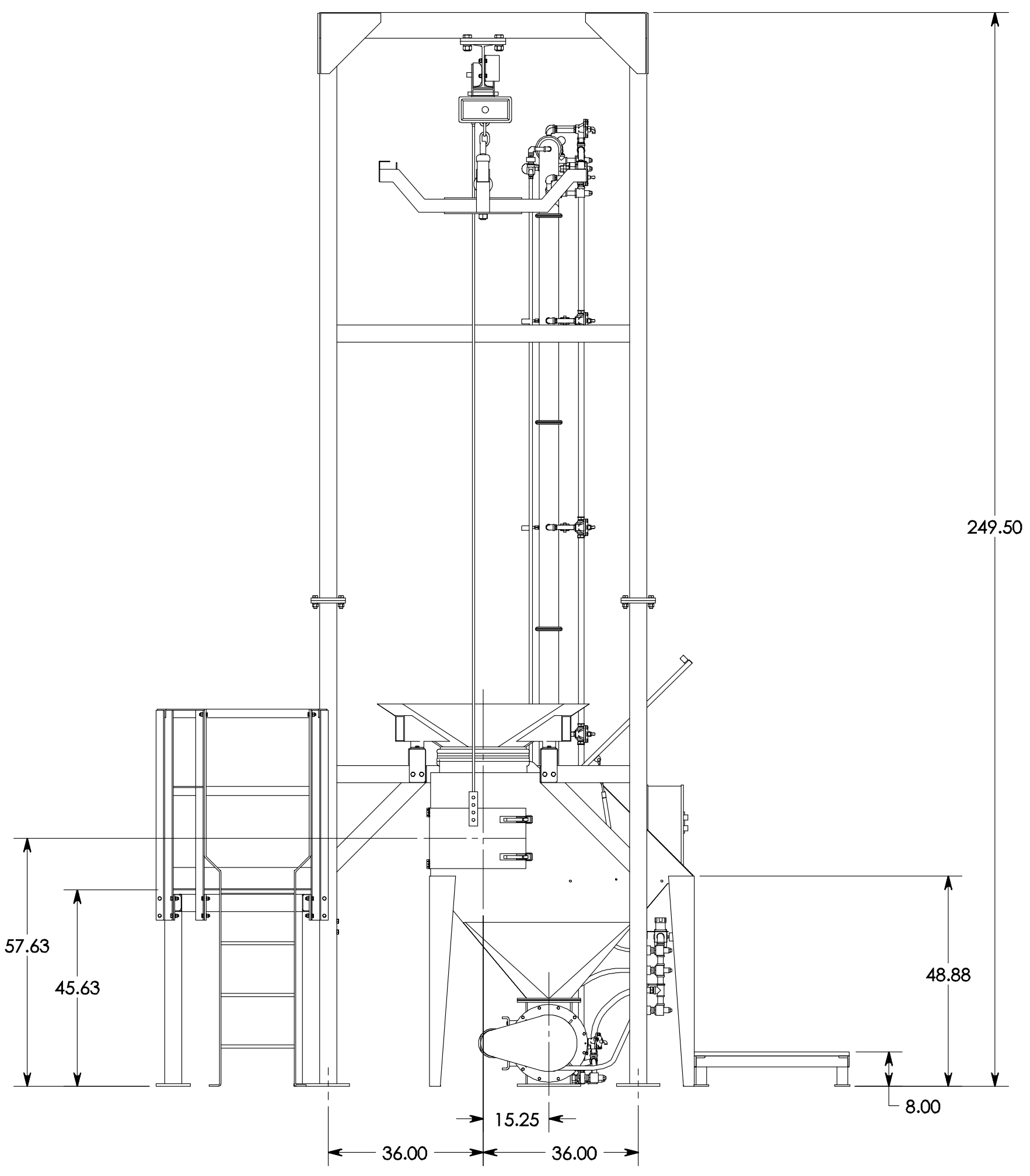
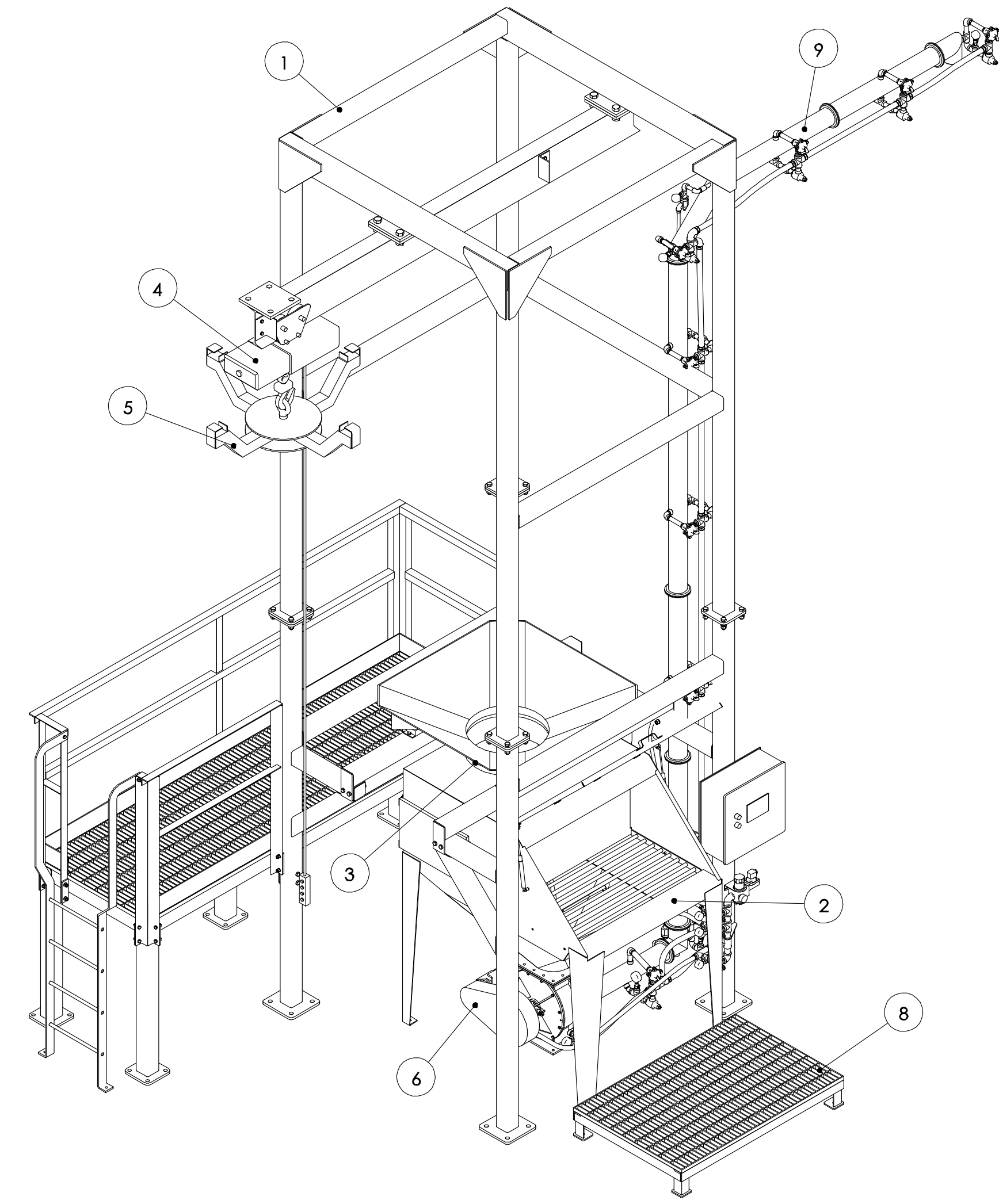
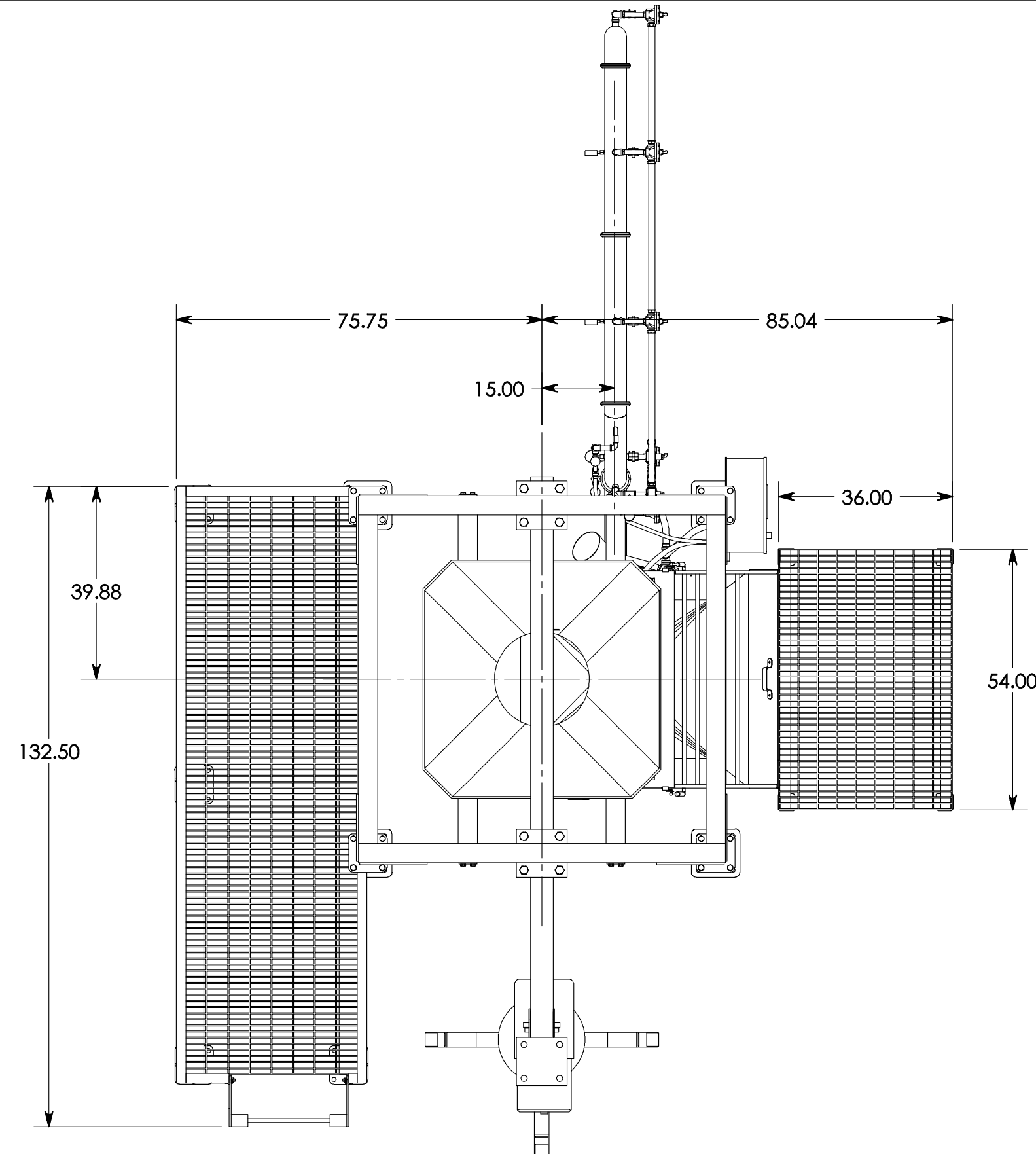

GENERAL TOLERANCES	
UNLESS OTHERWISE SPECIFIED THE FOLLOWING SHALL APPLY	
MACHINING	-.XX= .02 .XXX= .005 ANGLE= .50°
SURFACE ROUGHNESS	HEIGHT 63 MICROINCHES OR LESS
FABRICATION	UNDER 6 6 TO 24 24 TO 60 OVER 60
	± .06 ± .12 ± .19 ± .25
UNLESS OTHERWISE SPECIFIED DIMENSIONS ARE IN INCHES	

REV. NO.	DESCRIPTION	DATE	BY
3			
2			
1	GENERAL REVISION	08 12 02	AEB

REVISIONS

CUSTOMER Cabot Canada
 CUST. NO. 3842
 YOUNG ORDER NO. 14881
 TITLE

ASSEMBLY:
 BULK BAG/BAG DUMP UNLOADING STATION
 WITH STINGER FEEDING SYSTEM

THE YOUNG INDUSTRIES, INC.	
MUNICIPALITY, PENNSYLVANIA 17756	
TELEPHONE: 570-546-3165	
Drawn By AEB	SCALE 1:25
CHECKED BY	DATE 07/30/02
DRAWING NUMBER D-20064-00.01	